

Interchangeability of Screws/Nuts & Tightening Tools

螺絲、螺帽與鎖緊工具的互換性

The Murphy screws principle says: “If you are looking for four identical screws, you will definitely find only three.”

In such a case, the question of the interchangeability of the screws and the tightening tools is legitimate. However, as we will see below, not all bolts/nuts and tightening tools are interchangeable. In this article, we will try to specify it in concrete cases.

Some Practical Examples

A frequent source of errors is the cross groove on screws. Many people, even professionals, think that there is a universal type of cross slot and they can use with any cross screwdrivers. Despite their similar appearance, these two systems are not interchangeable (Fig. 1). The expert has surely already noticed why. The reason for this is the different shapes of the glossy contact surfaces of the PH (Phillips) and PZ (Pozidrive) systems. Interchanging them could damage not only the bit itself, but also the tightening groove on the screw. And the worst solution would be to use a flat screwdriver for a cross slot. Unfortunately, this also happens in practice.



Another example of prohibited interchange is incorrect orientation of fastening nuts of vehicles wheels (Fig. 4). Wrong assembly direction can cause loosening of the wheel during movement. Official statistics do not show the full truth, because there are not many drivers, who will admit that loosening of the wheel was their fault.

Example of possible interchange is trilobular screw (Fig. 5). Special property of this type of trilobular screw is the ability to make counter

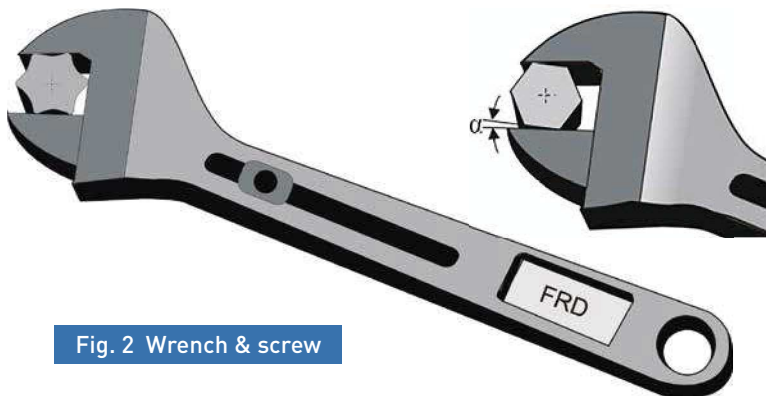

As you can see in Fig. 2, screws are often tightened by popular French keys. It is important to highlight though that it is not advised to use this assembly tool multiple times, because the edges are being damaged quickly (transmission of torque is done only through the edge). It is nicely demonstrated by Fig. 3a. For this reason, tightening with arc-screw (Fig. 3b) is much better (transmission of torque is done through bigger surface).

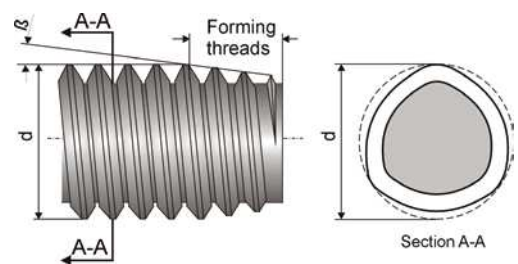
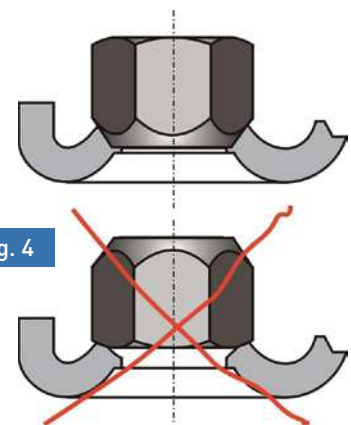
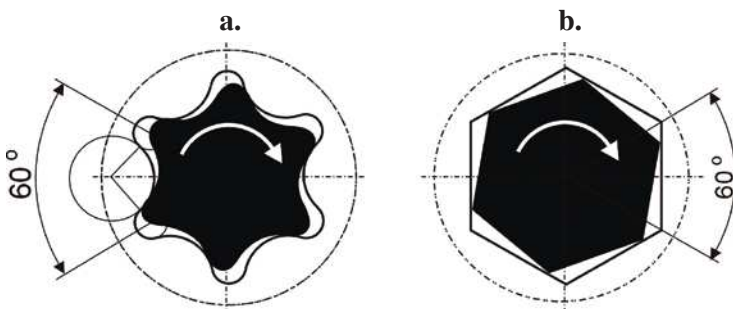

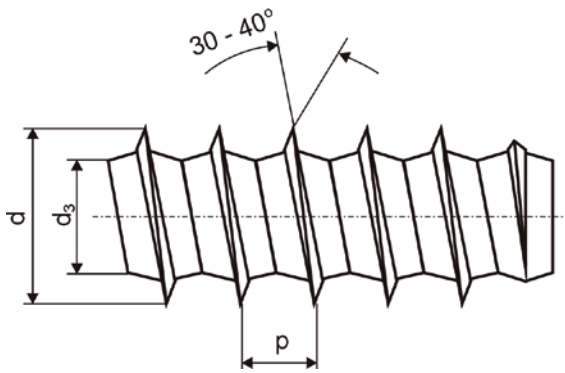

Fig. 6 Screw with threads dedicated to plastic

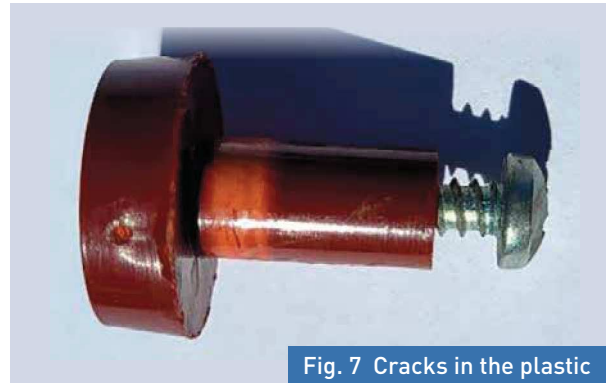

Fig. 7 Cracks in the plastic

counter threads during assembly by rolling - without making splinters. It is interchangeable with any other metrical screw of the same diameter. Trilobular screws can in extreme cases be used as a tool to make internal threads.

The Screw with threads dedicated to plastic (**Fig. 6**) is not interchangeable by any other. In the case where it happens, cracks can emerge in the plastic (**Fig. 7**).

Conclusion

As we have seen, there are many ways to use screws and screw drivers wrongly. There are many cases of impossible interchangeability. Not knowing about interchangeability can be damaging to both screws and screw drivers, which can further lead to collapse of construction units. A common example is bad application of fastening screws/nuts of automobile wheels, which can, for the reason of poor application of tightening moment or use of bad strength class, lead to very dangerous loosening of the wheel. ■

Article by Jozef Dominik and Dominik Makuka / Copyright owned by Fastener World

